



MC7010
The Quick Start Guide

View this label to get the default Password.

┌

Scan this QR code to download the Install Helper application.



LEGAL INFORMATION

Copyright © 2021 ZTE CORPORATION

All rights reserved.

No part of this publication may be quoted, reproduced, translated or used in any form or by any means, electronic or mechanical, including photocopying and microfilm, without the prior written permission of ZTE Corporation.

Notice

ZTE Corporation reserves the right to make modifications on print errors or update specifications in this guide without prior notice.

Disclaimer

Images and screenshots used in this guide may differ from the actual product. Content in this guide may differ from the actual product or software.

Trademarks

ZTE and the ZTE logos are trademarks of ZTE Corporation.



Other trademarks and trade names are those of their respective owners.

Version No.: R1.0

Unpacking and Preparations

Before installing the device, make sure that all items listed in the packing list are present. If something is missing or damaged, please contact ZTE technical support.

Packing List

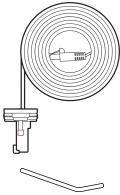
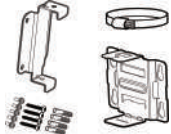
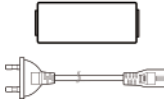
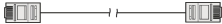

The MC7010 ODU CPE	The Quick Start Guide	1 Cover plate kit: Anti-theft screw*2, Screw anti-theft removal wrench*1, one CAT5E Network cable (for connecting the device and the POE adapter)
		
Mounting Kit: Metal bracket, Backplane, Metal clamp, M6 expansion bolts & M6 expansion spigots*4, M3 crosshead screws*5	1 POE adapter and AC Power cord	1 RJ-45 Network cable (for connecting the POE adapter and PC/Router)
		

Prepare the following accessories (not included):

- Crosshead screwdriver
- Flat head screwdriver
- Hammer drill
- Marker pens

Installation Precautions

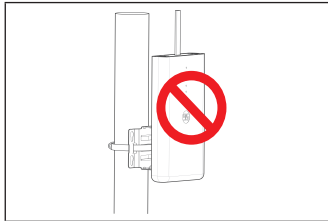
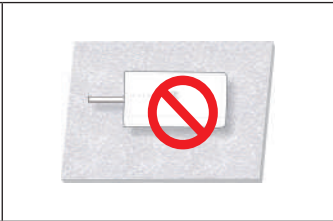
- Do not install the device in the following directions:

		
Do not install the device with the interface side facing upwards.	Do not install the device horizontally.	Do not install the device tilted.

WARNING!

The device must be installed downwards and vertically. It is not recommended to install the device in other directions (including but not limited to the above scenarios). ZTE is not liable for any problem caused by the installation in other incorrect directions.



- Do not install the device at a high position (lightning area).
- The device must be placed in a well-ventilated environment for use. If possible, install the device in a place with less direct sunlight, for example, in the shade. The device must not be installed at the outlet of the exhaust pipe, or installed in a place where water passes through, for example, a rain shed.
- The device shall be installed in the position of the site survey design drawings and within the protection range of 45° of the lightning rod. In high mountains and areas with heavy lightning (the number of thunderstorm days per year exceeds 180), ensure that the device is within the protection range of 30° of the lightning rod.
- When the device is mounted on the wall, it should better be more than 1 m away from the grounding cable of the lightning rod and more than 20 cm away from the lightning protection zone.
- When installing the device against a pole, do not install a lightning rod on the pole. It is recommended that an independent lightning rod be installed near the pole. If a lightning rod is installed on the pole, it is recommended that the lightning rod be led out and grounded directly.
- The mounting pole must be firm, cannot be shaken and must meet the wind-

resistant requirements (not less than level-10 wind speed).

- The mounting pole should be vertical, and the vertical error should be less than $\pm 2^\circ$.

Installation Modes

You can install the device in either of the following ways:

	
Install the device on a wall.	Install the device against a pole.

Requirements of Installation Space

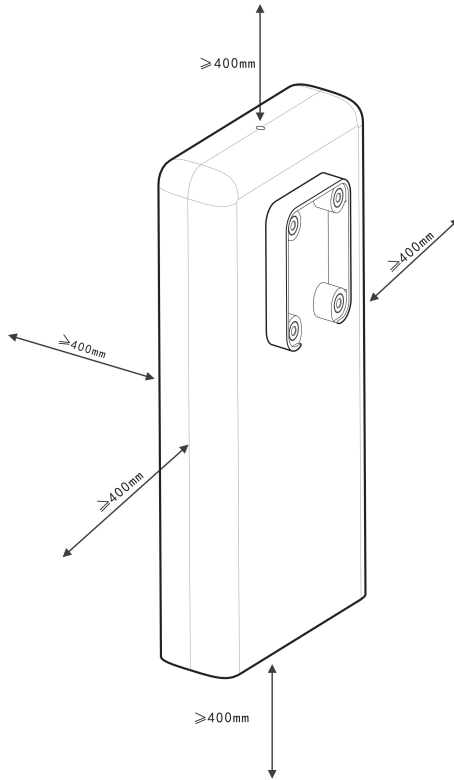

Recommended Installation Locations



1. Installing the nano-SIM Card

Insert the nano-SIM card to the SIM card slot as shown.

 **WARNING!**

Your device does not support (U) SIM cards, micro-SIM cards or any other non-standard SIM cards. To avoid damage to the device, do not use those cards or any card holders.

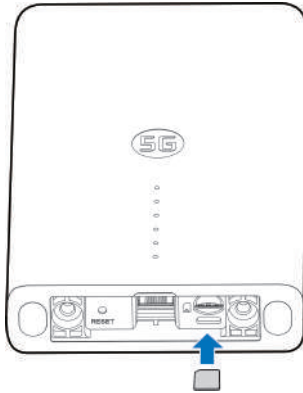

2. Installing the Network Cable

1. Connect the RJ45 to the network port on the MC7010 while the two screws are also inserted into the holes at the bottom of the device.

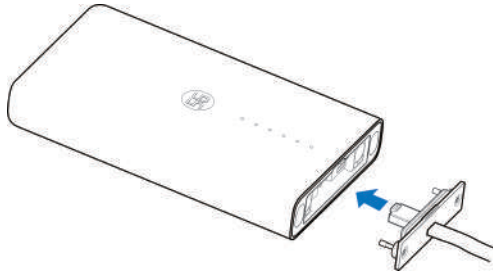

2. Push the cover plate upwards until it is secured, and use a screw anti-theft removal wrench to install the cover plate on the device.



3. Reserve enough length of the network cable, and crimp the RJ45.

3. Using Install Helper Application to Detect Position

Before installing the MC7010, you can install the Install Helper application on your mobile phone and connect to the device to detect the signal strength and help you detect and locate the installation location.

 **NOTE:**

View the label on this guide to get the link or QR code to download the Install Helper application.

Powering on the MC7010

1. Connect the CAT5E network cable which is from the MC7010 to the network port (RJ45-2) on the POE adapter.
2. Connect the power connector on the POE adapter to the socket.

Connecting to the MC7010

Before connecting to the device, make sure that you have installed the Install Helper application and turn on Bluetooth[®] of your phone.

1. Open the app list and touch **Install Helper**.
2. Touch **CONNECT TO DEVICE** and select **MC7010**. The Bluetooth of the device will turn on automatically, and your phone automatically scans for and displays the IDs of all available Bluetooth devices in range.
3. Touch the device you want to pair with.
4. Touch **PAIR & CONNECT > PAIR** to accept the connection.
5. Enter the password and touch **OK** to manage the device.

 **NOTE:**

View the label on this guide to get the default password.

Detecting and Adjusting Installation Position

1. Move the device around the mounting wall/pole or try different positions and touch **DETECT POSITION**.
2. Follow the on-screen instructions to attach the device to your target position, and slowly move it until it provides feedback.



NOTE:

The device does not support elevation angle adjustment. It only supports horizontal 180° adjustment.

3. The signal strength at the current position is displayed (Perfect, Great, Good, Poor and Terrible). You can touch **view details** to view the network details.

When the device signal is detected, your phone automatically beeps. The louder the sound and the stronger the vibration, the better the signal strength.



NOTE:

Touch **FINISH** to end the detection and select whether to save the current position if needed.

4. Continue the detection until the desired position is detected, and save or continue to adjust the position as prompted.

Powering off the MC7010

After the installation position is determined, disconnect the POE adapter from the device.

4. Installing Your Device

Installing the Device on a Wall

1. Mark the positions for drilling holes on the wall.

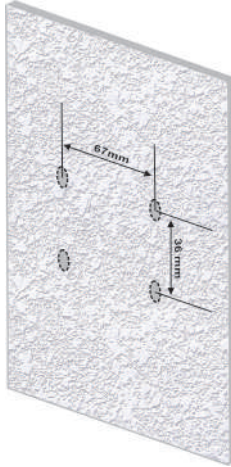

2. Firstly, use a 6mm percussion drill to drill holes at the marked positions, and install four M6 expansion spigots. Secondly, use four M6 expansion bolts to fix the bracket to the wall.

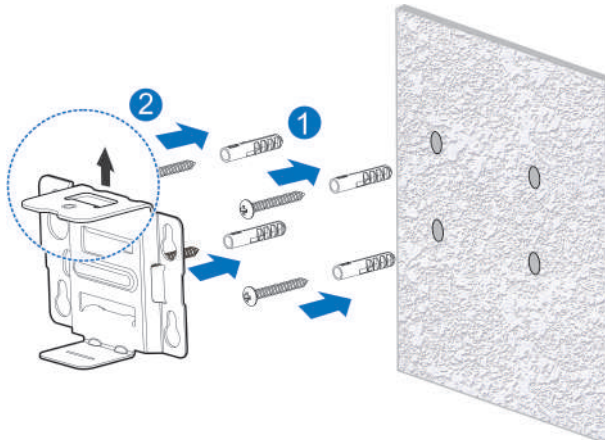

! CAUTION:

The screw hole of the bracket faces upwards. Do not install the bracket upside down. Otherwise, the screw cannot be installed later.

3. Use four M3 crosshead screws to install the backplane on the device.

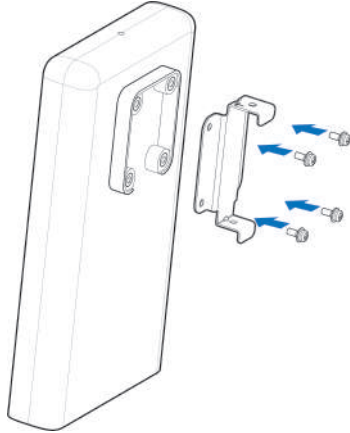

4. Firstly, fasten the backplane to the installed bracket through the upper and lower slots, and align the hole on the backplane with the hole on the bracket. Secondly, use one M3 crosshead screw to install the MC7010 on the bracket.

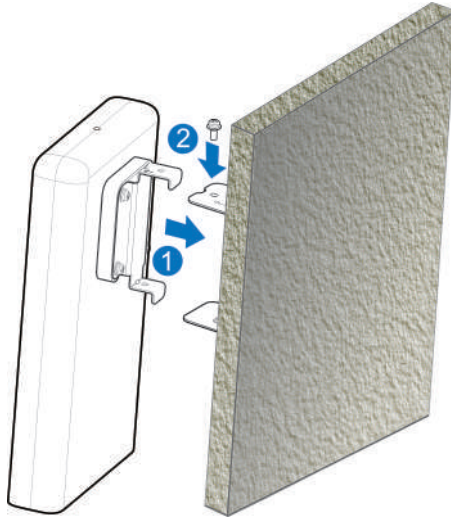

Installing the Device against a Pole

1. Use a screwdriver to loosen the clamp and release the buckle.

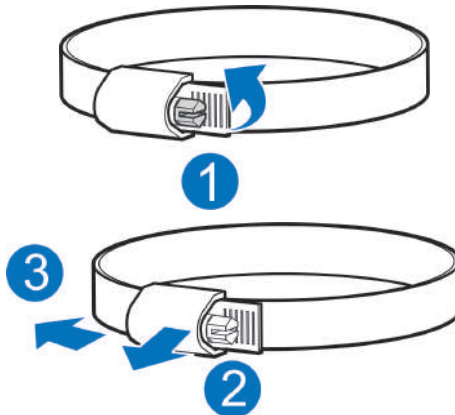

2. Pass the clamp through the U-shape groove on the bracket to install the bracket against the pole.

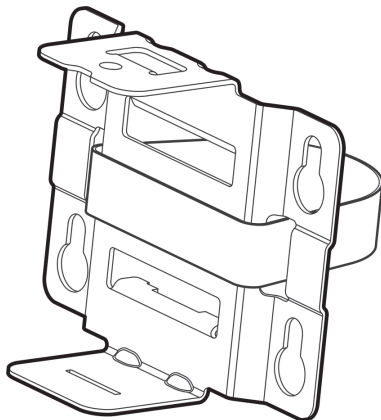

! CAUTION:

The screw hole of the bracket faces upwards. Do not install the bracket upside down. Otherwise, the screw cannot be installed later.

3. Adjust the clamp to the proper tightening position, press the buckle and use a screwdriver to lock the clamp to fix the bracket.

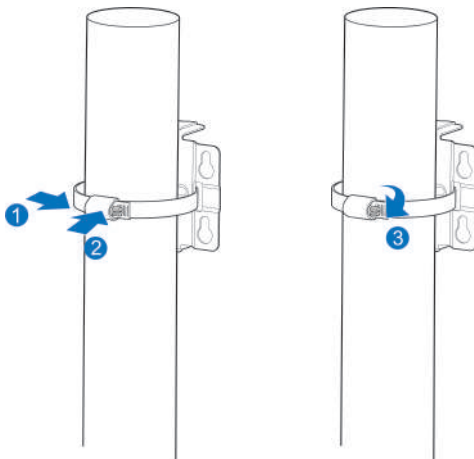

4. Use four M3 crosshead screws to install the backplane on the device.

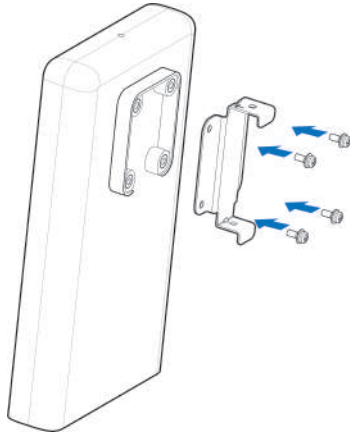

5. Firstly, fasten the backplane to the installed bracket through the upper and lower slots, and align the hole on the backplane with the hole on the bracket. Secondly, use one M3 crosshead screw to install the MC7010 on the bracket.

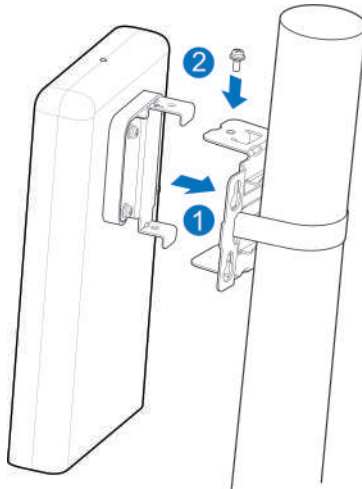

 **NOTE:**

Before installing the device on the bracket, you can move the device horizontally and slowly on the pole to further adjust the position if needed.

5. Connecting the POE Adapter

1. Connect the CAT5E network cable which is from the MC7010 to the network port (RJ45-2) on the POE adapter.
2. Connect the PC network port (RJ45-1) on the POE adapter to your PC/IDU (router) with the RJ-45 network cable.

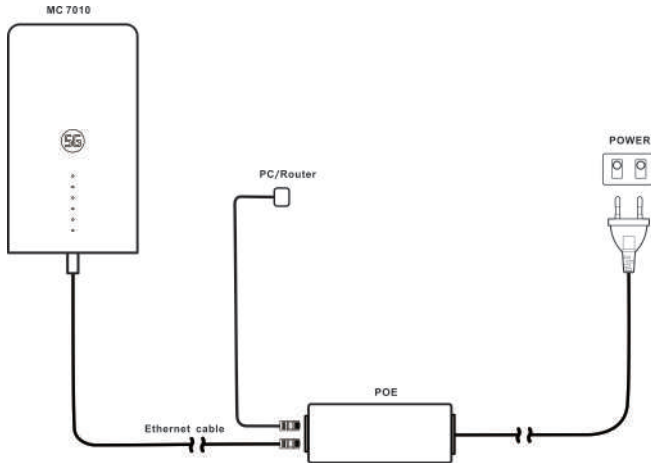

Installation Check

Device Installation:

- The MC7010 is installed firmly.
- The network cables are installed firmly.
- The cover plate on the device is installed.
- The nano-SIM card is installed.
- The network interface on the POE adapter is installed correctly.

Cables Installation:

- Verify that all cables are connected properly, cable connectors are secure.
- Cables should be laid in a clear and straight manner without crossing each other. There is no obvious curve or slant. Cables do not hang in the air or cross each other.

System Power-On

Powering on the device

Connect the power connector on the POE adapter to the socket. The POE adapter starts to supply power to the MC7010. When the indicator of the POE adapter and the POWER LED of the device turns green, the MC7010 is correctly powered on.

Preliminary Device Acceptance

1. Check indicator status.
2. Connect the device to a PC and log in to the configuration page to view the device status.

LED Behavior

When setting up the MC7010, the LED will have the following behavior.

Indicator	Status	Description
POWER	On	Power is on and external power supply is working normally.
	Off	Power is off.
NETWORK	Red blinking	The device is in error status: <ul style="list-style-type: none">• The device is not registered to the mobile network.• There is no nano-SIM card inserted.• There is no network service available.
	Green on	The device is registered or connected to the 5G network and data is being transferred.
	Green blinking	The device is connected or connected to the 3G/4G LTE network and data is being transferred.
LAN	Green on	The LAN port is connected.
	Green blinking	Data is being transferred.
	Off	The LAN port is not connected.
SIGNAL (Three lights)	On	Three lights show the signal strength. More lights on means better signals.
	Off	There is no signal or no nano-SIM card is inserted.

NOTES:

- All light indicators will be switched off automatically after the device operates normally for about 15 minutes. If indicators need to be solid, you could change their settings from the configuration web page of the 5G CPE.
- When a problem occurs, indicators will be automatically lighted up again to help you check the device status. After the problem is resolved, indicators will be turned off immediately.

Logging in to the 5G CPE Page

1. Ensure that the connection between your device and the PC/ router is correct.
2. Launch the Internet browser and enter <http://192.168.254.1> in the address bar.
3. Enter the password for access to the configuration web page of the 5G CPE.

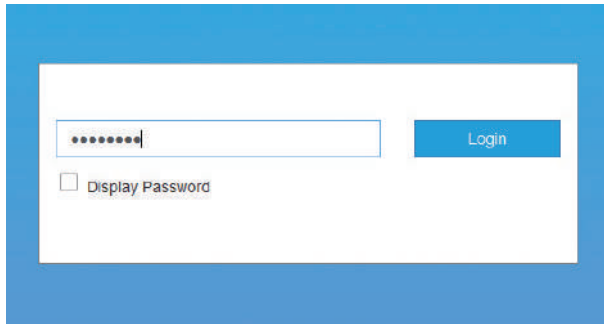

A screenshot of a login page for a 5G CPE. The page has a blue header and a white content area. In the center, there is a white rectangular box containing a password input field with a blue border and a blue 'Login' button to its right. The password field contains ten black dots. Below the password field is a checkbox labeled 'Display Password'.

NOTE:

View the label on this guide to get the default password.

Accessing the Internet

After a PC/router is successfully connected to your device, you can access the Internet in **Automatic** or **Manual** mode. The default mode is **Automatic**.

Mode	Operation
Automatic	Your device is automatically connected to the Internet, and you can surf on the Internet through the router.
Manual	<ol style="list-style-type: none">1. Log in to the 5G CPE configuration page.2. Select network Settings > Connection Mode > Manual, and then click Apply.3. Click  to return to the home page, and click  or .



NOTES:

- To change the current connection setting, please disconnect from the Internet first.
- To modify the parameters of your device, log in to the 5G CPE configuration page.

Confirming the Connection Status and Making More Settings

Confirming the Connection Status

The connection status related information is displayed when you log in to the configuration home page, and the Status Information below shows the information about **System information**, LAN details, Cellular connection status, WAN connection status and advanced status details. You can touch **Detail Information** to get more details. To see details on the connected session, touch **Data Usage** at the bottom left of the page.

Making More Settings

At the bottom left of the home page, you can send **SMS**, add **Phonebook** and touch **Advanced Settings** to make more settings of your device.

Troubleshooting

Problem	Recommended Action
The PC/router connected to the device cannot access the Internet.	<ul style="list-style-type: none">• Ensure that your nano-SIM card is available.• Change the location and find a place with good signal.• Check the settings of the LAN connection mode.• Contact your service provider and confirm your APN settings.
The 5G CPE configuration page cannot be visited.	<ul style="list-style-type: none">• Enter the correct address. The default address is http://192.168.254.1.• Use only one network adapter in your PC.• Do not use any proxy server.



NOTE:

You can press and hold the **RESET** button at the bottom of the device for about 3 seconds to restore your device to the factory settings if needed.

Getting More Help

If you experience some troubles with your Internet for home service you could get help by calling Telenor Customer Service at +35989123.

Warning and Notice

Radio Frequency Interference

General Statement on Interference

Some electronic devices may be susceptible to electromagnetic interference. Locate the device away from TV set, radio and other electronic equipment to avoid electromagnetic interference.

Medical Equipment

- Switch off your wireless device when you are requested to do so in hospitals, clinics or healthcare facilities. These requests are designed to prevent possible interference with sensitive medical equipment.
- Care must be taken when using your device in close proximity to personal medical devices, such as pacemakers and hearing aids.
- Please consult your doctor and the medical device manufacturers to determine if the operation of the device may interfere with the operation of your medical devices.

Explosive Environments

- Do not use your device in dangerous environments such as petrol stations or chemical factories where there are explosive gases or explosive products being processed. In locations with potentially explosive atmospheres, obey all posted signs to turn off wireless devices.
- Areas with potentially explosive atmospheres include fueling areas, below decks on boats, fuel or chemical transfer or storage facilities, and areas where the air contains chemicals or particles, such as grain, dust, or metal powders.
- Do not store or transport the device in containers with flammable liquids, gases, or explosives.

Product Handling

- Please keep yourself at least 20 centimeters away from your device.
- To avoid circuit malfunctions, do not use the device in dusty, damp or dirty environments or close to magnetic fields.
- Before connecting or disconnecting the device cable, stop using the device and disconnect the power adapter. You should keep your hands dry during the operation.

- When placing your device, keep it away from electrical appliances with strong magnetic or electric fields, such as microwave ovens and refrigerators.
- Do not expose your device or its accessories to liquid, moisture or high humidity. Keep them in a well-ventilated and cool environment away from direct sunlight.
- Keep your device or its accessories away from sources of heat and fire. High temperature can shorten the life of electronic devices.
- Do not wrap, seal or cover the device with towels or other objects. Do not use the device in a closed environment such as a box to avoid damage to the device due to poor heat dissipation.
- Do not allow the device or accessories to come into contact with liquid or moisture at any time. Do not immerse the device in any liquid.
- Your device may become warm during normal use. If the device temperature is too high, do not touch it.
- Do not touch the antenna unnecessarily.
- Do not drop, throw or try to bend your device or its accessories.
- Do not paint your device or its accessories.
- Do not allow children to play with the device or power adapter. Doing so may result in damage or explosion.

Small Children

- Do not leave your device and its accessories within the reach of small children or allow them to play with it. They could hurt themselves or others, or could accidentally damage the device.
- Your device contains small parts with sharp edges that may cause an injury or may become detached and create a choking hazard.

Accessories

- Please use original accessories or accessories that are authorized by ZTE. Unauthorized accessories may affect the device performance, damage the device or cause danger to you.
- Using other types of accessories may void the device warranty, violate the local regulations and laws, and cause an accident. To obtain approved accessories, please contact an authorized service center.

Electrical Safety

- For pluggable equipment, the socket-outlet shall be installed near the equipment and shall be easily accessible.
- The power plug is intended as a device to disconnect the power.
- When the device is not in use, please unplug the power adapter from the power outlet and the device.
- Do not drop or hit the power adapter. If it is damaged, please contact an authorized service center for inspection.
- If the power plug or power cable is damaged, stop using it immediately. Continued use may cause electric shock or fire.
- Do not touch the power cable with wet hands, or pull the power cable to disconnect the power adapter.
- To avoid short circuit, malfunction or electric shock, do not touch the device or power adapter with wet hands.
- When the power adapter is exposed to rain, liquid or severe moisture, stop using it and contact an authorized service center for inspection.

Cleaning and Maintenance

- The recommended operating temperatures are $-40\text{ }^{\circ}\text{C}$ to $+55\text{ }^{\circ}\text{C}$ and the storage temperatures are $-40\text{ }^{\circ}\text{C}$ to $+70\text{ }^{\circ}\text{C}$. The humidity range is 5% ~ 95%.
- During storage, transportation, and use of the device, keep it dry and avoid sharp collisions with other objects.
- Keep the device and its accessories dry. Do not use external heating devices such as microwave ovens or hair dryers to dry them.
- Do not place the device and its accessories in areas where the temperature is too high or too low. Otherwise, the device may malfunction, catch fire or explode.
- Do not cause strong impacts to the device and its accessories. Otherwise, the device may malfunction, catch fire or explode.
- When not using the device for a long period, power it off and remove all cables connected to it.
- If any abnormal phenomenon (such as smoke, unusual sound or peculiar smell) occurs, stop using it immediately, disconnect the power adapter, unplug all cables connected to the device, and contact an authorized service center.
- Do not step on, pull, or excessively bend the device cables. Otherwise the

cables may be damaged and the device may malfunction.

- Before cleaning and maintenance, stop using the device, close all applications, and disconnect all cables connected to it.
- Use an antistatic cloth to clean the device and its accessories. Do not use harsh chemicals, cleaning solvents, or aerosols to clean them. Power off your device before you clean it.
- Do not attempt to disassemble the device or its accessories. Unauthorized disassembly or modification will void the warranty.
- Only qualified personnel can service or repair the device or its accessories. If your device (or its accessories) has been submerged in water, punctured, or subjected to a severe fall, do not use it until you have taken it to be checked at an authorized service center.

Environmental Protection

- Do not dispose of the device and its accessories as household garbage.
- Please comply with your local laws and regulations regarding the disposal of the device and its accessories.

Limited Warranty

This warranty does not apply to defects or errors in the product caused by:

- i. Reasonable abrasion.
- ii. End users' failure to follow ZTE's installation, operation or maintenance instructions or procedures.
- iii. End users' mishandling, misuse, negligence, or improper installation, disassembly, storage, servicing or operation of the product.
- iv. Modifications or repairs not provided by ZTE or a ZTE-certified individual.
- v. Power failures, surges, fire, flood, accidents, and actions of third parties or other events outside ZTE's reasonable control.
- vi. Usage of third-party products or usage in conjunction with third-party products if such defects are due to the combined usage.
- vii. Any other cause beyond the range of normal usage intended for the product.

End users have no right to reject or return the product, or receive a refund for the product from ZTE under the above-mentioned situations.

This warranty is end users' sole remedy and ZTE's sole liability for defective or nonconforming items, and is in lieu of all other warranties, expressed, implied or

statutory, including but not limited to the implied warranties of merchantability and fitness for a particular purpose, unless otherwise required under the mandatory provisions of the law.

Limitation of Liability

ZTE shall not be liable for any loss of profits or indirect, special, incidental or consequential damages resulting from or arising out of or in connection with using of this product, no matter whether or not ZTE had been advised, knew or should have known of the possibility of such damages, including, but not limited to lost profits, interruption of business, cost of capital, cost of substitute facilities or product, or any downtime cost.

RF Exposure

This equipment complies with CE radiation exposure limits set forth for an uncontrolled environment. This equipment should be installed and operated with minimum distance of 20 cm between the radiator and your body.

Specification

This radio equipment operates with the following frequency bands and maximum radio-frequency power.



NOTE:

All ZTE products are compliant with these power limits required by the European Union. Frequency bands supported by the product vary by model.

WCDMA BAND 1/2/4/5/8: 23dBm

FDD LTE BAND 1/2/3/4/7/25/30/32/66: 22.5dBm

FDD LTE BAND 5/8/12/17/20/26/28: 23dBm

TDD LTE BAND 34/38/39/40/41/42/43: 22.5dBm

5G NR(PC3): n1/3/7/8/20/28/38/40/77: 22.5dBm

5G NR(PC3): 41/78/79: 24.5dBm

5G NR(PC2): n1/3/7/8/20/28/38/40/77: 26dBm

5G NR(PC2): 41/78/79: 26dBm

Bluetooth LE: 5dBm

CE Caution (Proper Use)

As described in this guide, your device can be used only in the right location. If possible, please do not touch the antenna area on your device.

Disposal of Your Old Appliance

	<ol style="list-style-type: none">1. When this crossed-out wheeled bin symbol is attached to a product, it means the product is covered by the European Directive 2012/19/EU.2. All electrical and electronic products should be disposed of separately from the municipal waste stream via designated collection facilities appointed by the government or the local authorities.3. The correct disposal of your old appliance will help prevent potential negative consequences for the environment and human health.
--	---

For this product's recycling information based on WEEE directive, please send an e-mail to weee@zte.com.cn

EU DECLARATION OF CONFORMITY



Hereby, ZTE Corporation declares that the radio equipment type ZTE MC7010 is in compliance with Directive 2014/53/EU.

The full text of the EU declaration of conformity is available at the following Internet address: <https://certification.ztedevices.com>

Compliance of Directive 2009/125/EC

The product meets the requirement of Directive 2009/125/EC and is compliant with its COMMISSION REGULATION (EC) No 1275/2008 and (EU) No 801/2013. For more information, please visit <https://certification.ztedevices.com>

ZTE CORPORATION

NO. 55, Hi-tech Road South, ShenZhen, P.R.China

Postcode: 518057